

Features

kWh Energy meter - 1-phase

Type 7E.12 10(25)A - 2 module wide

Type 7E.13 5(32)A - 1 module wide

Type 7E.16 10(65)A - 2 module wide

- Complies with EN 62053-21 and prEN 50470
- Certified by PTB (Physikalisch - Technischen Bundesanstalt)
- Accuracy class 1 / B
- Protection class II
- Pulse output for remote energy management; SO interface (open collector) according to DIN 43864 to link the energy meter to a centrally located monitoring/management system
- Tamper-proof cover with lead seal facility available as an accessory
- Space saving small size
- 35 mm rail (EN 60715) mount
- MID compliant versions available



7E.12.8.230.0002



- Nominal current 10 A (25 A Maximum)
- 1-phase 230 V AC
- 35 mm wide

7E.13.8.230.0000



- Nominal current 5 A (32 A Maximum)
- 1-phase 230 V AC
- 17.5 mm wide

7E.16.8.230.0000



- Nominal current 10 A (65 A Maximum)
- 1-phase 230 V AC
- 35 mm wide

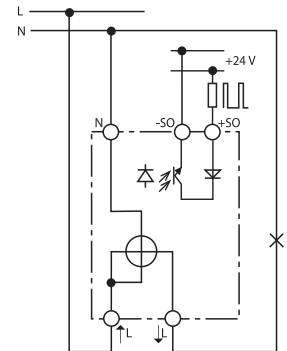
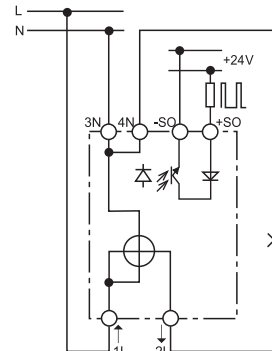
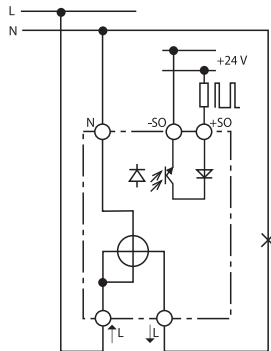

For outline drawing see page 5

Specification				
Nominal/Maximum current measuring	A	10/25	5/32	10/65
Minimum measured current	A	0.04	0.02	0.04
Current range (within accuracy class)	A	0.5...25	0.25...32	0.5...65
Maximum peak current	A	750 (10 ms)	960 (10 ms)	1,950 (10 ms)
Supply (& monitored) voltage	V AC	230	230	230
Operating range		$(0.8...1.15)U_N$	$(0.8...1.15)U_N$	$(0.8...1.15)U_N$
Frequency	Hz	50/60	50/60	50/60
Rated power	W	< 0.5	< 0.4	< 0.5
Display, Reading (digit height 4 mm)		Six digit counter, red decimal digit	Seven digit counter, red decimal digit	
Max. totalising count/Min. totalising count kWh		99,999.9/0.1	999,999.9/0.1	999,999.9/0.1
LED- Pulses per kWh		2,000	2,000	1,000
Open collector- output specification (SO+/SO-)				
Voltage (external supply)	V DC	5...30	5...30	5...30
Maximum current	mA	20	20	20
Maximum leakage current @30 V/25 °C	µA	10	10	10
Pulses per kWh		1,000	1,000	1,000
Pulse length	ms	50	50	50
Internal series resistance	Ω	100	100	100
Maximum Cable length (30 V/20 mA)	m	1,000	1,000	1,000
Technical data				
Accuracy class		1 / B	1 / B	1 / B
Ambient temperature (Within accuracy class)	°C	-10...+55	-10...+55	-10...+55
Protective class		II	II	II
Protection category: Housing/terminal		IP 50/IP 20	IP 50/IP 20	IP 50/IP 20
Approvals (according to type)		CE	CE PTB	

Features

kWh Energy meter - 3-phase

Type 7E.36-0000 10(65)A - Single tariff

Type 7E.36-0002 10(65)A - Dual tariff

- Complies with EN 62053-21 and prEN 50470
- Certified by PTB (Physikalisch - Technischen Bundesanstalt)
- Accuracy class 1 / B
- Protection class II
- Pulse output for remote energy management; SO interface (open collector) according DIN 43864 to link the energy meter to a centrally located monitoring/management system
- Tamper-proof cover with lead seal facility available as an accessory
- 35 mm rail (EN 60715) mount
- MID compliant versions available

7E.36.8.400.0000



- Nominal current 10 A (65 A Maximum)
- 3-phase
- 70 mm wide

7E.36.8.400.0002



- Nominal current 10 A (65 A Maximum)
- 3-phase
- Dual tariff (Day and Night)
- 70 mm wide

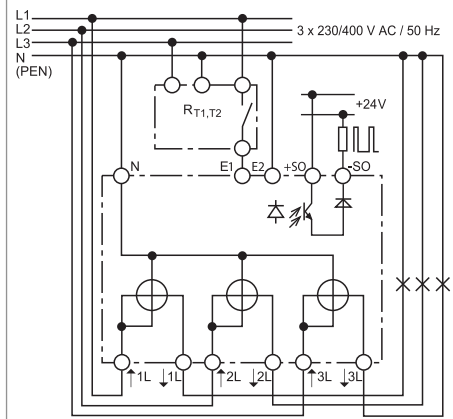
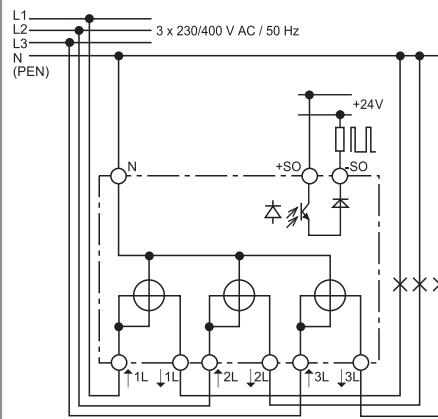

$R_{T1,T2}$ = Tariff switching equipment

For outline drawing see page 5

Specification			
Nominal/Maximum current measuring	A	10/65	10/65
Minimum measured current	A	0.04	0.04
Current range (within accuracy class)	A	0.5...65	0.5...65
Maximum peak current	A	1,950 (10 ms)	1,950 (10 ms)
Supply (& monitored) voltage	V AC	3 x 230	3 x 230
Operating range		$(0.8...1.15)U_N$	$(0.8...1.15)U_N$
Frequency	Hz	50/60	50/60
Rated power per phase	W	< 1.5	< 1.5
Display, Reading, Indication		Seven digit counter, red decimal digit, digit height 4 mm	
Max. totalising count/Min. totalising count kWh		999,999.9/0.1	999,999.9/0.1
LED- Pulses per kWh		100	100
Open collector- output specification (SO+/SO-)			
Voltage (external supply)	V DC	5...30	5...30
Maximum current	mA	20	20
Maximum leakage current @30 V/25 °C	µA	10	10
Pulses per kWh		100	100
Pulse length	ms	50	50
Internal series resistance	Ω	100	100
Maximum Cable length (30 V/20 mA)	m	1,000	1,000
Technical data			
Accuracy class		1 / B	1 / B
Ambient temperature	°C	-10...+55	-10...+55
Protective class		II	II
Protection category: Housing/terminal		IP 50/IP 20	IP 50/IP 20
Approvals (according to type)		CE PTB	

Ordering information

Example: Energy meter 32 A/230 V AC, with PTB certified, accuracy class 1, available with Tamper-proof lead sealed cover as accessory, for 35 mm rail (EN 60715) mounting.

7	E	.	1	.	3	.	8	.	2	3	0	.	0	0	0	0
Series			Function			Current			Supply version			Special version				
			1 = 1-phase 3 = 3-phase			2 = 25 A 3 = 32 A 6 = 65 A			8 = AC 50/60 Hz			0 = Standard 1 = MID compliant versions				
												Option				
												0 = Standard 2 = Standard (7E.12 only) 2 = Dual tariff (7E.36 only)				
												Supply voltage				
												230 = 230 V AC 50/60 Hz 400 = 3 x 230/400 V AC 50/60 Hz				
												All versions/width				
												7E.12.8.230.0002/35 mm		7E.36.8.230.0010/70 mm		
												7E.13.8.230.0000/17.5 mm		7E.36.8.400.0000/70 mm		
												7E.13.8.230.0010/17,5 mm		7E.36.8.400.0002/70 mm		
												7E.16.8.230.0000/35 mm				
												7E.16.8.230.0010/35 mm				

Technical data

Insulation EN 62053-21		7E.12, 7E.13, 7E.16		7E.36		
Insulation rated voltage	V	250		250		
Overvoltage category		IV		IV		
Isolation	between active part SO+/SO- terminals	kV (1.2/50 µs)	6		6	
	adjacent phases	kV (1.2/50 µs)	—		6	
Insulation	between supply and SO+/SO-	V AC	4,000		4,000	
	between adjacent phases	V AC	—		4,000	
Protection class		II		II		
EMC Specification		Reference standard				
Electrostatic discharge	contact discharge	EN 61000-4-2		8 kV		
	air discharge	EN 61000-4-2		15 kV		
Radio-Frequency Electromagnetic Field (80...1,000)MHz		EN 61000-4-3		10 V/m		
Fast Transients (Burst) (5-50 ns, 5 kHz)	on Supply Terminals	EN 61000-4-4		Class 4 (4 kV)		
	on SO+/SO- Terminals	EN 61000-4-4		Class 4 (2 kV)		
Surge (1.2/50 µs)	on Supply Terminals	EN 61000-4-5		Class 4 (4 kV)		
	on SO+/SO- Terminals	EN 61000-4-5		Class 3 (1 kV)		
Radio-Frequency Common Mode (0.15...80)MHz on Supply terminals		EN 61000-4-6		10 V		
Radiated and Conducted Emission		EN 55022		Class B		
Other data						
Pollution degree		2				
Vibration resistance	(10...60)Hz	mm	0.075			
	(60...150)Hz	g	1			
Vibration resistance of the internal mechanical counter (10...500)Hz	g	2				
Schock resistance	g/18 ms	30				
Schock resistance of the internal mechanical counter	g/18 ms	350				
Power lost to the environment	without current	W	7E.12, 7E.13		7E.16	7E.36
	with maximum current	W	1		2	6
Supply terminals						
Max. wire size	mm ²	7E.12, 7E.13		7E.16, 7E.36		
		solid cable	stranded cable	solid cable	stranded cable	
		1...6	0.75...4	1.5...16	1.5...16	
		18...10	18...12	16...6	16...6	
Screw torque for I _{max}	Nm	0.8...1.2		1.5...2		
Screw		M4 Pozidrive No.1, Phillips No.1, Flat No.1				
SO+/SO- terminals						
Max. wire size	mm ²	solid cable	stranded cable	solid cable	stranded cable	
		2.5	1.5	2.5	1.5	
	AWG	14	16	14	16	
Screw torque for I _{max}	Nm	0.5		0.8		
Screw		M3 Pozidrive No.1, Phillips No.1, Flat No.1		M4 Pozidrive No.1, Phillips No.1, Flat No.1		

LED indication (Normal operation)

Type	Energy consumption			Pulses per kWh	Pulse space	The LED Pulse rate represents the instantaneous power being consumed, according to the following
	None	Low	High			
7E.12 7E.13				2,000	100 ms	$kW = (\text{number of pulse per Minute}) / 33.3$
7E.16				1,000	100 ms	$kW = (\text{number of pulse per Minute}) / 16.7$
7E.36				100	150 ms	$kW = (\text{number of pulse per Minute}) / 1.7$

LED indication (Abnormal operation)

Status indicates errors of installation, as below

Type	Abnormal operation status		
7E.12 7E.13 7E.16	Device ON, incorrect connection (L-N inverted). Mark = 600 ms, Space = 600 ms 		
7E.36	Mark = 100 ms, Phase L1 ↑ L1 ↓ inverted or loss 	Phase L2 ↑ L2 ↓ inverted or loss 	Phase L3 ↑ L3 ↓ inverted or loss
	Phase L1 ↑ L1 ↓ and L2 ↑ L2 ↓ inverted or loss 	Phase L1 ↑ L1 ↓ and L3 ↑ L3 ↓ inverted or loss 	Phase L1 ↑ L1 ↓ and L2 ↑ L2 ↓ and L3 ↑ L3 ↓ inverted or loss

SO+/SO- Open collector output wiring diagram

The pulsating open collector output available at terminals SO+ and SO- can be interfaced with the input of a computer, plc or other energy management equipment to allow the remote monitoring of energy consumed.

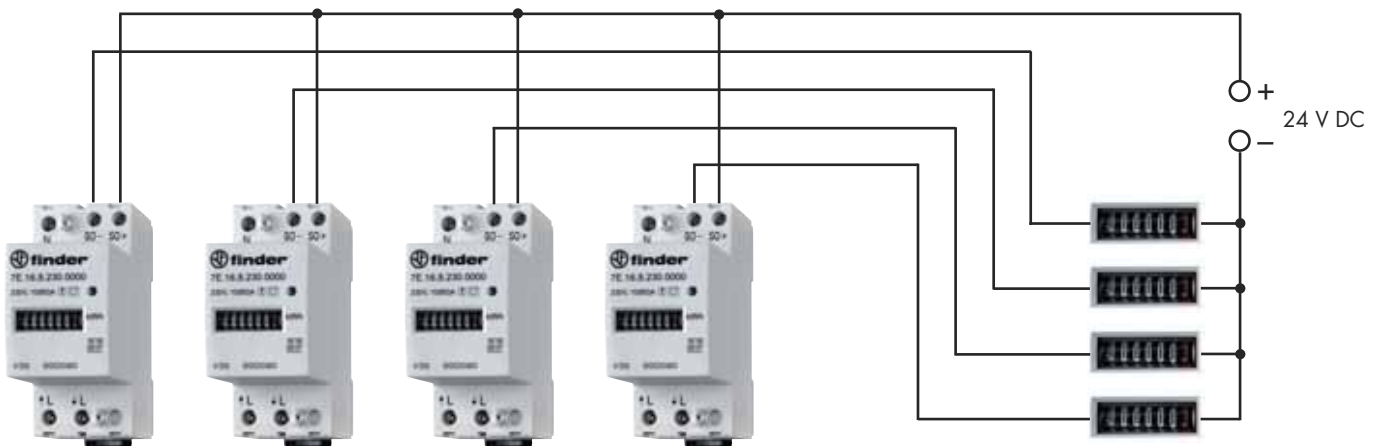

Energy meters – at difference locations
(Note: Both Single and Dual tariff meters provide only a single pulsating output)

Central monitoring/management system
(max. 20 mA for each input)

Outline drawing

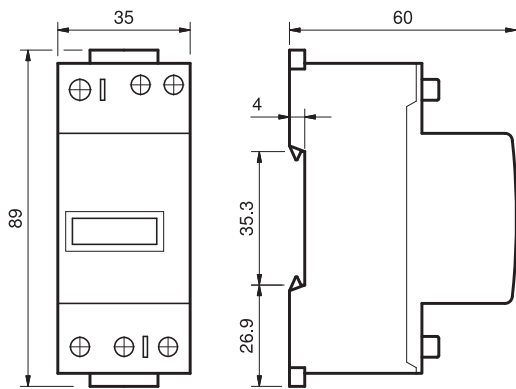

7E.12.8.230.0002 / 7E.16.8.230.0000

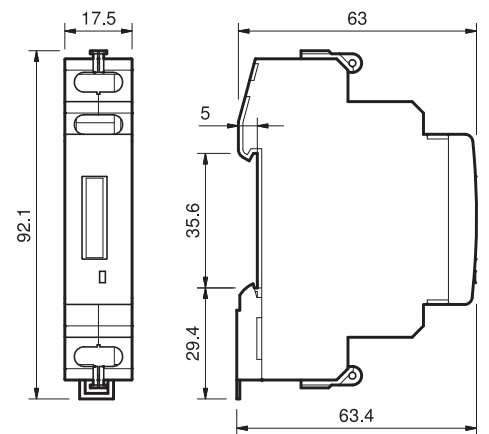

7E.13.8.230.0000

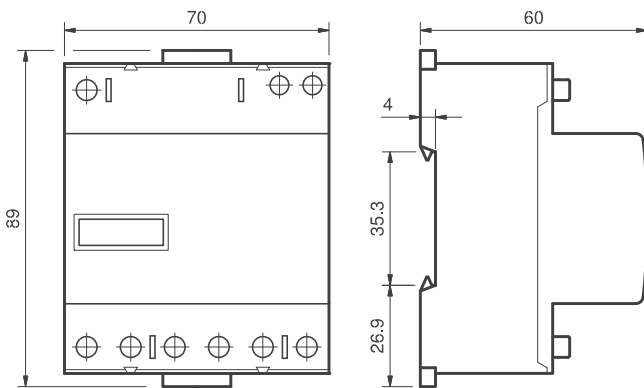

7E.36.8.400.0000

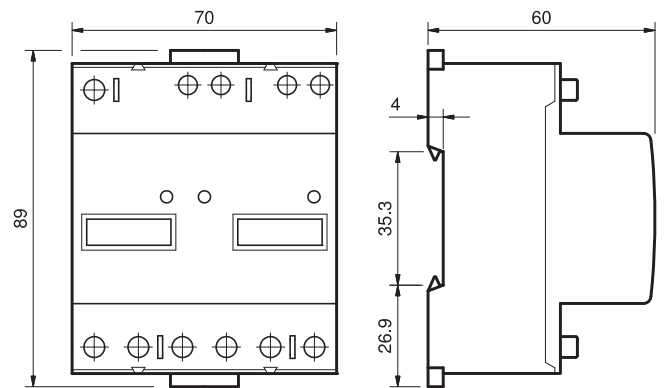

7E.36.8.400.0002

Accessories



07E.13

Terminal cover for type 7E.13
For the tamper-proof lead seal use 2 terminal cover

07E.13



07E.16

Terminal cover for type 7E.12, 7E.16 and 7E.36
7E.12, 7E.16 - For the tamper-proof lead seal use 2 terminal covers
7E.36 - For the tamper-proof lead seal use 4 terminal covers

07E.16